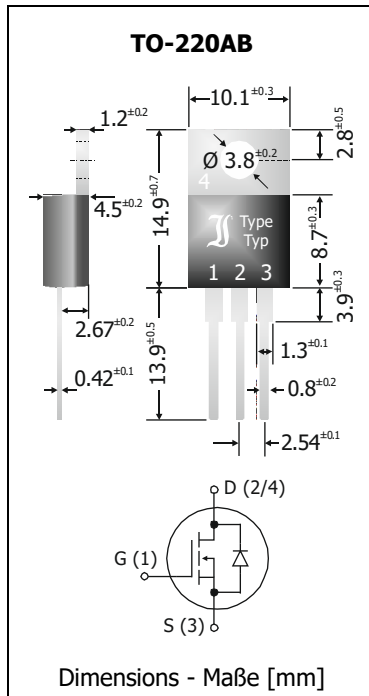

**DIT050N06**  
**N-Channel Power MOSFET**  
**N-Kanal Leistungs-MOSFET**

$I_{D25^{\circ}\text{C}}$  = 50 A  
 $R_{DS(\text{on})}$  ~ 14 m $\Omega$   
 $T_{j\text{max}}$  = 175 $^{\circ}\text{C}$

$V_{DSS}$  = 60 V  
 $P_D$  = 85 W  
 $E_{AS}$  = 245 mJ

Version 2020-01-27

**Typical Applications**

DC/DC Converters  
 Power Supplies  
 DC Drives  
 Power Tools  
 Commercial grade <sup>1)</sup>

**Features**

Advanced Trench Technology  
 Low on state resistance  
 Fast switching times  
 Low gate charge  
 Avalanche rated  
 Compliant to RoHS, REACH,  
 Conflict Minerals <sup>1)</sup>

**Mechanical Data <sup>1)</sup>**

Packed in tubes/cardboards 50/1000  
 Weight approx. 2.2 g  
 Case material UL 94V-0  
 Solder & assembly conditions 260 $^{\circ}\text{C}/10\text{s}$   
 MSL N/A

**Typische Anwendungen**

Gleichstrom-Wandler  
 Stromversorgungen  
 Gleichstrom-Antriebe  
 Elektrowerkzeuge  
 Standardausführung <sup>1)</sup>

**Besonderheiten**

Advanced Trench Technologie  
 Niedriger Einschaltwiderstand  
 Schnelle Schaltzeiten  
 Niedrige Gate-Ladung  
 Avalanche-Charakteristik  
 Konform zu RoHS, REACH,  
 Konfliktmineralien <sup>1)</sup>

**Mechanische Daten <sup>1)</sup>**

Verpackt in Stangen/Kartons  
 Gewicht ca.  
 Gehäusematerial  
 Löt- und Einbaubedingungen

**Maximum ratings <sup>1)</sup>****Grenzwerte <sup>2)</sup>**

		<b>DIT050N06</b>	
Drain-Source voltage Drain-Source-Spannung	$V_{GS} = 0 \text{ V (short)}$	$V_{DSS}$	60 V
Gate-Source-voltage continuous Gate-Source-Spannung dauernd		$V_{GSS}$	$\pm 20 \text{ V}$
Power dissipation Verlustleistung	$T_C = 25^{\circ}\text{C}^{\ 2)}$	$P_{\text{tot}}$	85 W
Drain current continuous Drainstrom dauernd	$T_C = 25^{\circ}\text{C}^{\ 3)}$	$I_D$	50 A
Drain current continuous Drainstrom dauernd	$T_C = 100^{\circ}\text{C}^{\ 3)}$	$I_D$	35 A
Peak Drain current – Drain-Spitzenstrom	<sup>3)</sup>	$I_{DM}$	90 A
Source current continuous Sourcestrom dauernd	$T_C = 25^{\circ}\text{C}^{\ 3)}$	$I_S$	30 A
Peak Source current – Source-Spitzenstrom	$V_{GS} = 0 \text{ V}, t_p = 300 \mu\text{s}$	$I_{SM}$	50 A
Single pulse avalanche energy Einzelpuls Avalanche-Energie (Fig. 1)	$V_{DD} = 35 \text{ V}, V_G = 10 \text{ V}$ $L = 0.5 \text{ mH}, R_G = 25 \Omega$	$E_{AS}$	245 mJ
Junction temperature – Sperrschichttemperatur Storage temperature – Lagerungstemperatur		$T_j$ $T_s$	-55...+175 $^{\circ}\text{C}$ -55...+175 $^{\circ}\text{C}$

1 Please note the [detailed information on our website](#) or at the beginning of the data book  
 Bitte beachten Sie die [detaillierten Hinweise auf unserer Internetseite](#) bzw. am Anfang des Datenbuches

1  $T_A = 25^{\circ}\text{C}$ , unless otherwise specified –  $T_A = 25^{\circ}\text{C}$ , wenn nicht anders angegeben

2 Measured at heat flange – Gemessen an der Kühlfahne

3 Pulse width refer to SOA diagram – Pulsbreite siehe SOA-Diagramm

**Characteristics (static)**
**Kennwerte (statisch)**

		$T_j = 25^\circ\text{C}$	Min.	Typ.	Max.
Drain-Source breakdown voltage – Drain-Source-Durchbruchspannung	$I_D = 250 \mu\text{A}$ $V_{GS} = 0 \text{ V (short)}$	$V_{(BR)DSS}$	60 V	–	–
Drain-Source leakage current – Drain-Source Leckstrom					
Gate-Body leakage current – Gate-Substrat Leckstrom	$V_{GS} = \pm 20 \text{ V}$ $V_{DS} = 0 \text{ V (short)}$	$I_{GSS}$	–	–	$\pm 100 \text{ nA}$
Gate-Source threshold voltage – Gate-Source Schwellspannung					
Drain-Source on-state resistance – Drain-Source Einschaltwiderstand	$V_{GS} = 10 \text{ V}$ $I_D = 20 \text{ A}$	$R_{DS(on)}$	–	14 m $\Omega$	20 m $\Omega$

**Characteristics (dynamic)**
**Kennwerte (dynamisch)**

		$T_j = 25^\circ\text{C}$	Min.	Typ.	Max.
Forward Transconductance – Übertragungsteilheit	$V_{DS} = 5 \text{ V}$ $I_D = 20 \text{ A}$	$g_{FS}$	18 S	–	–
Input Capacitance – Eingangskapazität	$V_{DS} = 30 \text{ V}$ $V_{GS} = 0 \text{ V}$ $f = 1 \text{ MHz}$	$C_{iss}$	–	2050 pF	–
Output Capacitance – Ausgangskapazität	$V_{DS} = 30 \text{ V}$ $V_{GS} = 0 \text{ V}$ $f = 1 \text{ MHz}$	$C_{oss}$	–	158 pF	–
Reverse Transfer Capacitance – Rückwirkungskapazität	$V_{DS} = 30 \text{ V}$ $V_{GS} = 0 \text{ V}$ $f = 1 \text{ MHz}$	$C_{rss}$	–	120 pF	–
Turn-On Delay & Rise Time – Einschaltverzögerung und Anstiegszeit	$V_{DD} = 30 \text{ V}$ $R_L = 6.7 \Omega$ $V_{GS} = 10 \text{ V}$ $R_G = 3 \Omega$ (Fig. 1)	$t_{d(on)}$ $t_r$	–	7.4 ns 5.1 ns	–
Turn-Off Delay & Fall Time – Ausschaltverzögerung und Abfallzeit	$V_{DD} = 30 \text{ V}$ $R_L = 6.7 \Omega$ $V_{GS} = 0 \text{ V}$ $R_G = 3 \Omega$ (Fig. 1)	$t_{d(off)}$ $t_f$	–	28.2 ns 5.5 ns	–
Total Gate Charge – Gesamte Gate-Ladung	$V_{DD} = 30 \text{ V}$ $I_D = 20 \text{ A}$ $V_{GS} = 10 \text{ V}$	$Q_g$	–	50 nC	–
Gate-Source Charge – Gate-Source-Ladung	$V_{DD} = 30 \text{ V}$ $I_D = 20 \text{ A}$ $V_{GS} = 10 \text{ V}$	$Q_{gs}$	–	6 nC	–
Gate-Drain Charge – Gate-Drain-Ladung	$V_{DD} = 30 \text{ V}$ $I_D = 20 \text{ A}$ $V_{GS} = 10 \text{ V}$	$Q_{gd}$	–	15 nC	–
Intrinsic Gate resistance – Innerer Gatewiderstand	$f = 1 \text{ Mhz}$ D open	$R_{Gi}$	–	tbd $\Omega$	–

**Fig. 1**

Test circuit for switching times (R) and avalanche energy (L) ("rise" and "fall" refer to  $I_D$ )  
 Testaufbau für Schaltzeiten (R) und Avalanche-Energie (L) ("rise" und "fall" beziehen sich auf  $I_D$ )

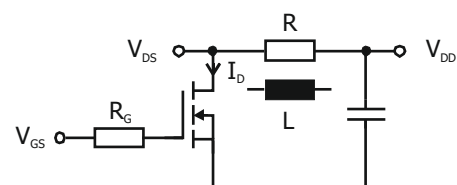
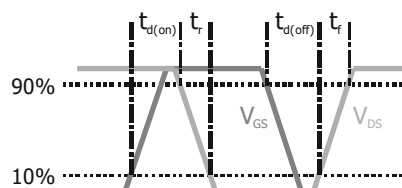

**Characteristics (diode)**

**Kennwerte (Diode)**

		$T_j = 25^\circ\text{C}$	Min.	Typ.	Max.
Forward voltage – Durchlass-Spannung $V_{GS} = 0\text{ V}$ $I_S = 20\text{ A}$		$V_{SD}$	–	–	1.2 V
Reverse recovery time – Sperrverzugszeit $I_S = 20\text{ A}$ , $di/dt = -100\text{ A}/\mu\text{s}$		$t_{rr}$	–	28 ns	–
Reverse recovery charge – Sperrverzugsladung $I_S = 20\text{ A}$ , $di/dt = -100\text{ A}/\mu\text{s}$		$Q_{rr}$	–	40 nC	–

**Characteristics (thermal)**

**Kennwerte (thermisch)**

		Min.	Typ.	Max.	
Thermal resistance junction to case Wärmewiderstand Sperrschicht – Gehäuse		$R_{thc}$	–	1.7 K/W <sup>1)</sup>	–

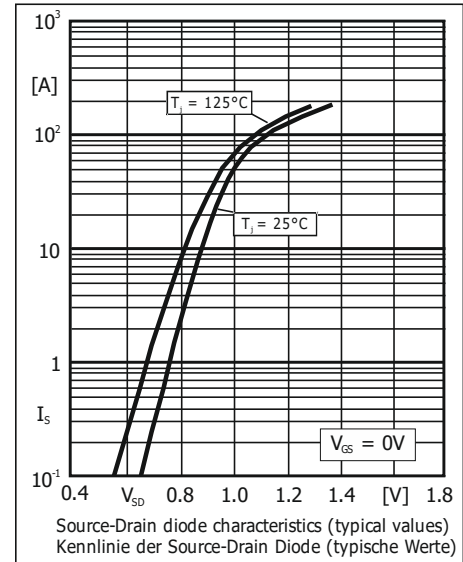
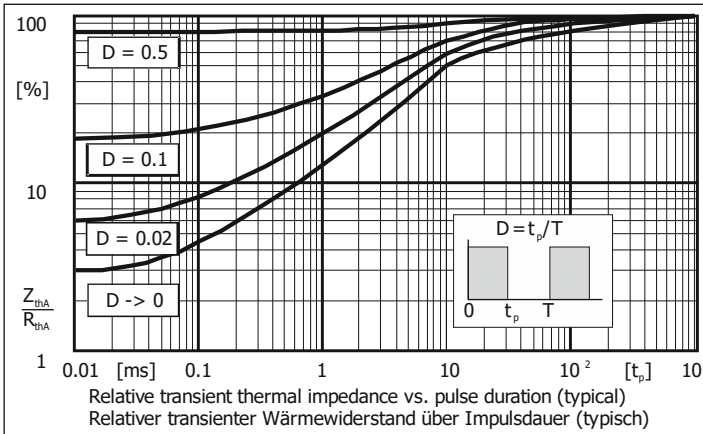

**Disclaimer:** See data book page 2 or [website](#)  
**Haftungsausschluss:** Siehe Datenbuch Seite 2 oder [Internet](#)

1 Measured at heat flange – Gemessen an der Kühlfahne